

Base Connector SHW

The **Base Connector SHW160** is the optimal connection between the robot and its base. It takes only seconds to change out the robot or place it into a different application. The intuitive and safe operation will make your robot more flexible.

The **Base Connector SHW160** is compatible with all light robots / cobots with a max payload of approximately 8 kg and a robot weight of approximately 25 kg. Please inform us of the robot manufacturer to ensure the correct drill hole pattern.

*** In case of extreme loads we recommend the Base Connector SWS200. Please consult us for the best configuration.**

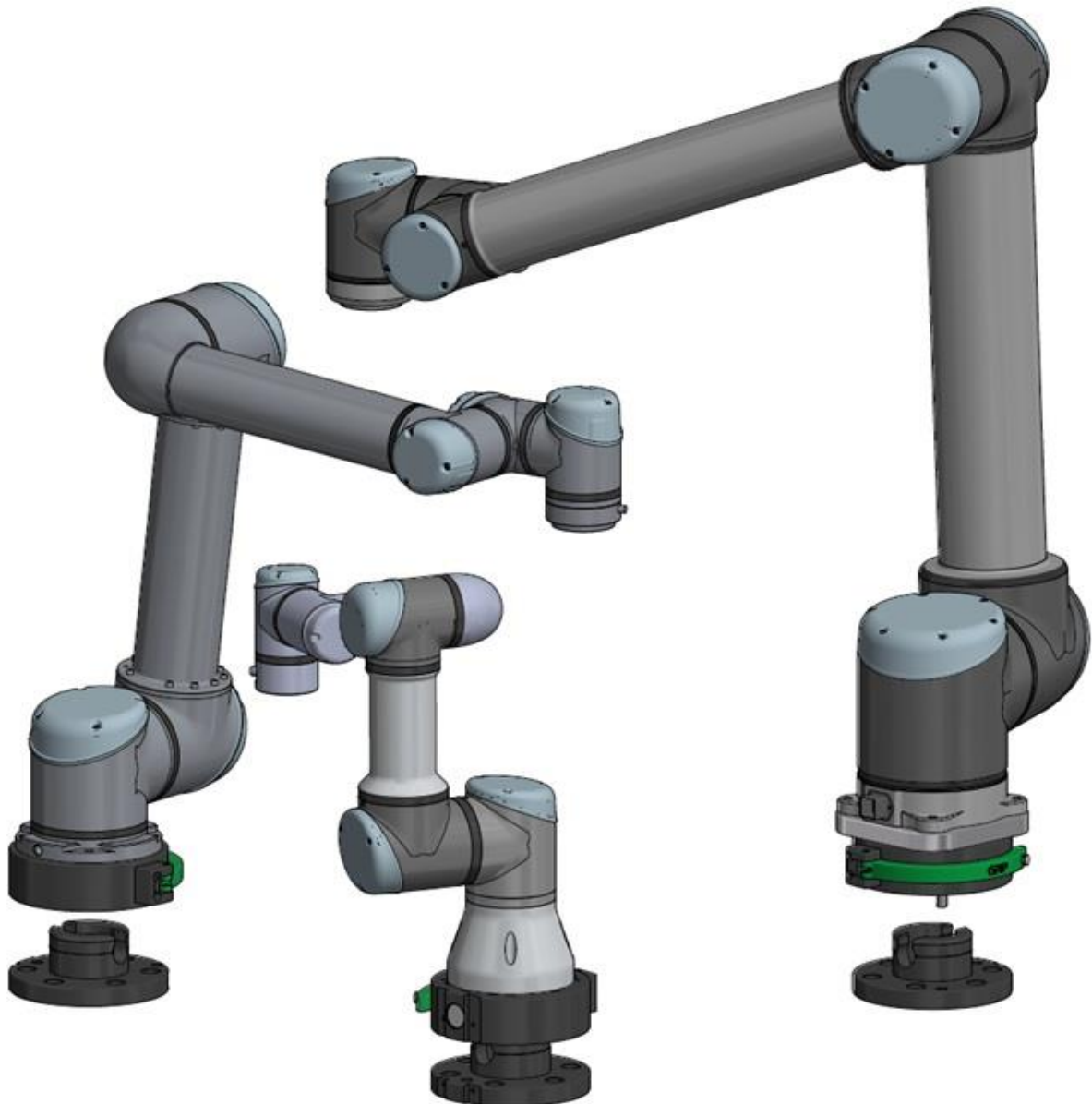

Base Connector SHW160

The **Base Connector SHW160** is the ideal mechanical connection for light robots. The intuitive operation is easy and does not require any tools.

The SHW upper assembly, as depicted in the drawing, is mounted to the base of the robot. The lower assembly is mounted to the work surface.

Pos.	Description
1	Robot
2	G-UF158-20 Universal flange (UR10+16) Aluminum 158x158x20
3	G-SHW160-2OE-UR SHW Connector Upper assembly
4	G-SHW160-2UE SHW Connector Lower assembly

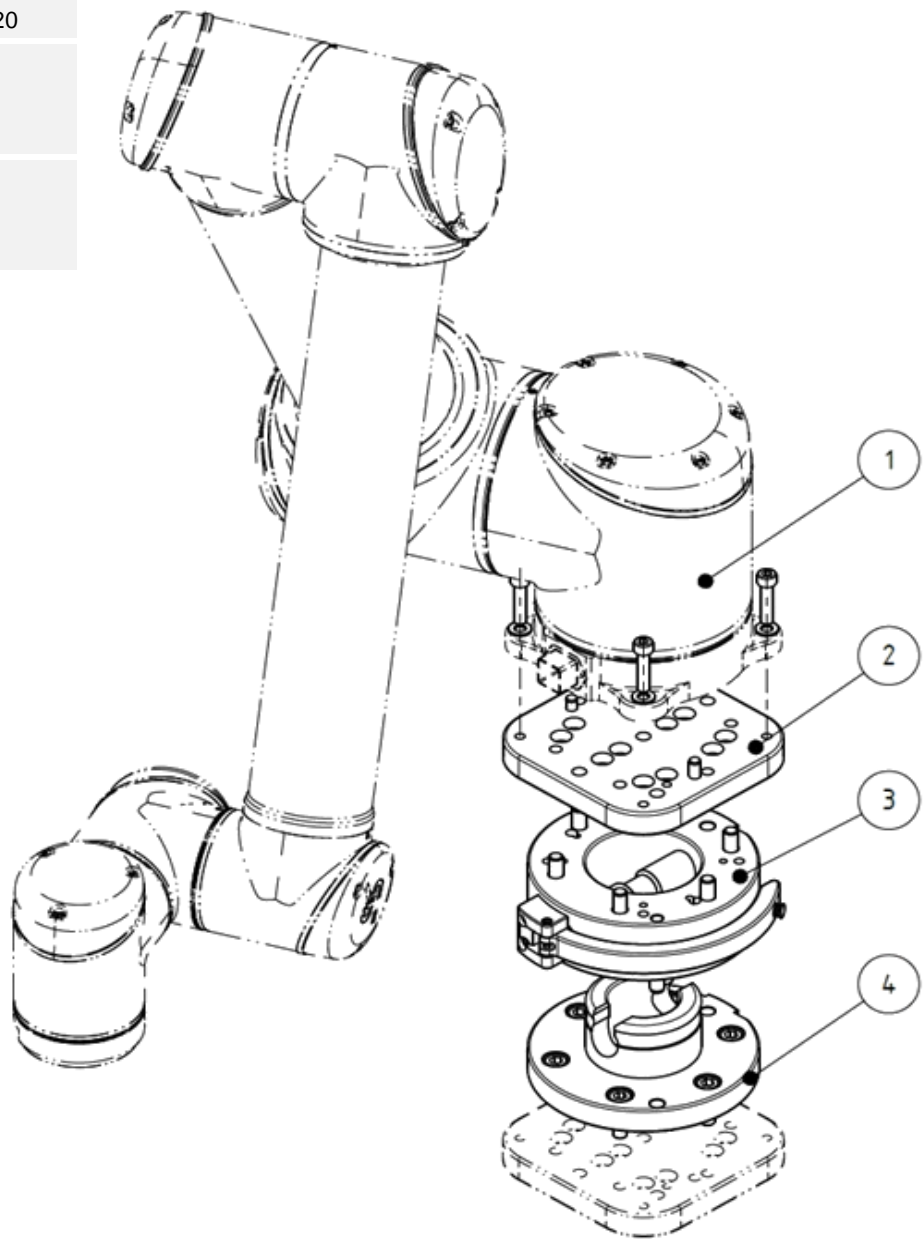

Base Connector SHW160

Technical specifications



Operating mode:

By operating the hand lever on the upper assembly (1), the crossway bolt is displaced radially. The crossway bolt is pressed into the bore of the lower assembly (2).

Advantages:

- Allows removal or installation of the entire robot arm within seconds
- Intuitive operation
- Can be released and closed with one handle
- High repeat accuracy +/- 0.02 mm
- Holds up to 5,000 changing cycles
- Interface according to DIN EN ISO 9409-1

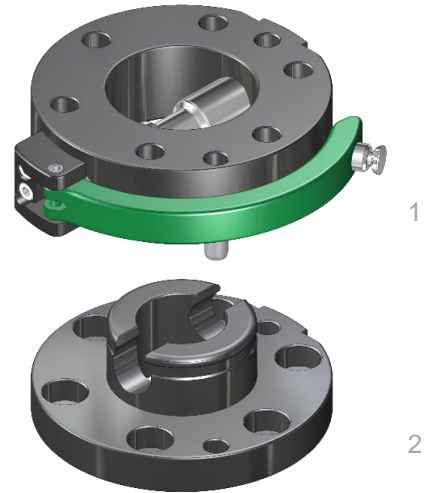

Technical specifications		SHW160
Basic material		Al. anod.
External diameter x height [mm]		160 x 70
Pitch circle diameter [mm]		125
Repeat accuracy +/- [mm]		0,02
Tension Fz [N]		2.000
Compression -Fz [kN]		626
Torsion Mz [Nm]		300
Bending Mx, My [Nm]		320
Mass [kg]	upper assembly	2,8
	lower assembly	1,2
Recommended load [kg]		25*
Locking force VF [N]		10 - 100
Locking stroke VH [mm]		0 - 1
Operating temperature range [°C]		-30 to +120
* This guideline applies to the following assumptions: Acceleration: 3 m/s², gravity distance: 500 mm, double safety		

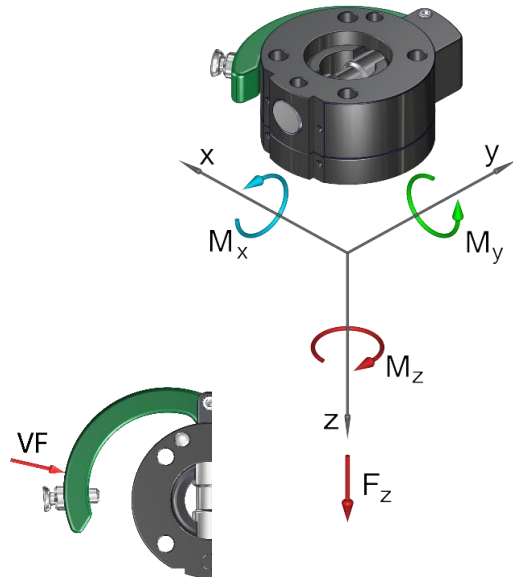

Pos.	Description
1	Upper assembly
2	Crossway bolt (CB)
3	Hand lever
4	Holder
5	Strap pin (SP)
6	Spring locking pin
7	Guiding screw
8	Index pin
9	Cylinder bolt SP
10	Cylinder bolt CB
11	Shim ring
12	Lower assembly

Thrust lever change system Ø160, drilled acc. to ISO...

G-SHW160-2OE-UR	upper assembly, E-Mount, Al, anodized, UR
G-SHW160-2UE	lower assembly, E-Mount, Al, anodized

