

TML200

Lifter Solution



The new ROEQ Top Module Lifter TML200 for the MiR250 is a flexible top module that can function as a lifter for pallets, crates and racks, as well as for shelf carts. As a lifter, crates or pallets can be picked up, transported and dropped off using the ROEQ PR250 pallet rack as a pick-up/drop off station. Depending on requirements, the pallet rack can be set against a wall or used as a free-standing rack that enables the mobile robot to deliver the load and continue driving through. The pallet rack can also be set up in multiples, side by side, for a scalable solution. In addition, the TML200 can pick up shelf carts (S-Cart300L) in free space, with no need for a docking station, allowing an operator to roll the cart away after drop-off. When the TML200 lifts the S-Cart300L, robot traction is increased, enabling the robot to operate more effectively in conditions of reduced friction, such as polished or dusty floors. This is a truly versatile solution to enable your MiR250 to transport different types of loads.

All ROEQ top modules come with the ROEQ Assist software tool which is fully compatible with MiR software. It reduces the integration time needed, assisting the setup of the system, and setting the right footprints for the robot to facilitate safe navigation. The tool builds standard missions to get you up and running faster.

Features

- Cargo sensor for detecting load on module – to avoid errors at pick up/drop off
- Mounting holes for attaching equipment e.g. TML200 Forks for lifting pallets
- Can lift S-Cart300L for transporting on floors with reduced friction
- IO kit can be purchased to add e.g. tower lights, extra emergency stop etc.
- ROEQ Assist software tool - integrates with MiR software for easier start up, set up and multiple tasks



Specifications

Robot compatibility:
MiR250

Payload:
200kg / 441lbs

Size (l x w):
780 x 560 x 70mm / 30.7" x 22" x 2.8"

Lifter height from floor:
including robot 365 - 405mm / 14.4" - 15.9"

Lifting surface:
655 mm x 495 mm / 25.8" x 19.5"

Weight:
35kg / 77.3lbs

ROEQ product compatibility:
PR250, TML200 Forks, S-Cart300L





Stroke:
40mm / 1.6"

Lifting time:
Full Load / No Load: 8/5 sec

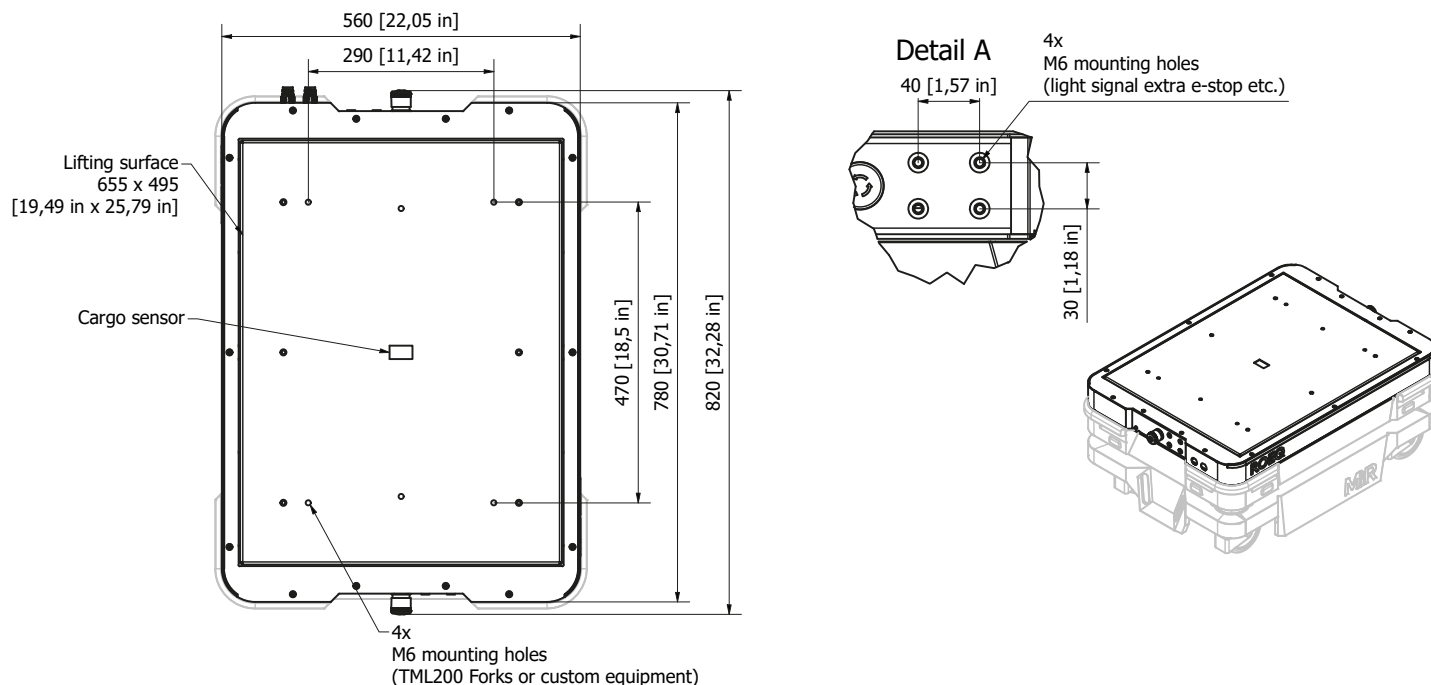
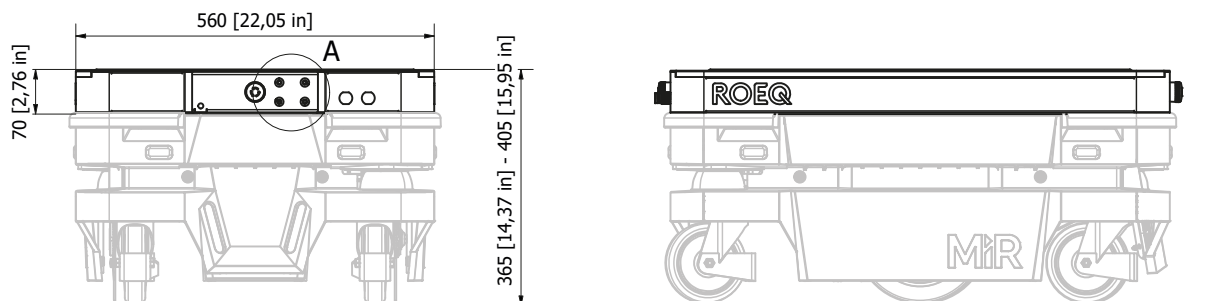
Sensors:
Cargo sensor range up to 20mm





Number	Product	Description	
277a1000	TML200	Top module lifter for MiR250	
270a9050	S-Cart300L	Designed to be lifted and transported by the TML200 - payload up to 170kg/374lbs.	
277a6000	PR250 (Pallet Rack)	Pallet Rack for pick up/drop off of pallets, crates etc. Adjustable width.	
277m7050	TML200 Forks	For TML200, when handling e.g. half euro pallets.	
277a8000	IO Kit 250	Input/output to the MiR250 for equipment e.g. light tower or extra emergency stop.	

Visit roeq.dk for more information or to see films of products in action.

Contact your local ROEQ Partner for more guidance