

Nord Cart 300-510

The Nord Cart 300-510 seamlessly integrates with the MiR250 robot, enabling efficient pick-up and delivery of objects placed on the cart anywhere within the production site. Designed for flexibility, the Nord Cart can accommodate various custom applications or solutions tailored to the customer’s specific needs. Its design allows the AMR to precisely detect and position itself beneath the cart for easy transport.

The Nord Cart is available in three configurations: basic cart, a model with a handle, a configuration with pallet tray (half pallet tray).

MiR | **Go** Approved

Have been tested and validated by Mobile Industrial Robots



Specifications

MiR compatibility	MiR250	Product code	SC300-510-02
Variations	Basic cart, with handle, with pallet tray, with half-pallet tray		
Max. payload capacity	300 kg 661 lbs		

Specifications may vary based on local conditions and application

Product Description

Designated use	Transport of good by merging with the Nord Quick Mover
Seamless Payload Transfer	Interface perfectly with the Nord Quick Mover
Handle	Ergonomic manual handling. Allows for easy manual maneuvering and precise positioning by operators
Pallet tray	Full-size pallet support. Designed for secure transport of standard pallets
Half pallet tray	Compact load optimization. Ideal for half-pallets, maximizing space efficiency
Secure Engagement	Specialized design ensures a stable connection for safe and reliable transport
Compact, Robust and Reliable Design	Features a small footprint, simple and fast assembly, and a robust construction for continuous operation
Reliable operation with minimal maintenance	Designed for 24/7 operation with minimal maintenance

Compatibility



Nord Quick Mover 220-510



Plug-and-Play Design



Maintenance-Free Engineering



Rapid Deployment Ready



Optimized for Maximum ROI

Dimensions

Length 615 mm | 24.2 in

Width 894 mm | 35.2 in

Height 624 mm | 24.6 in

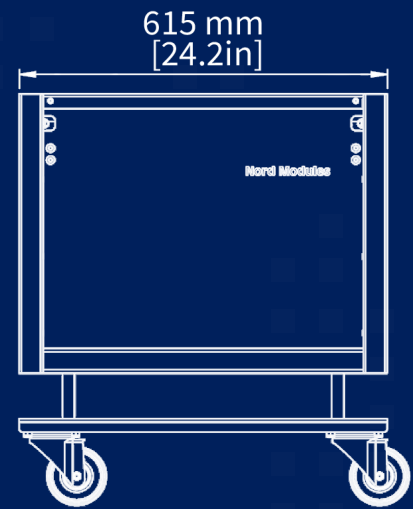
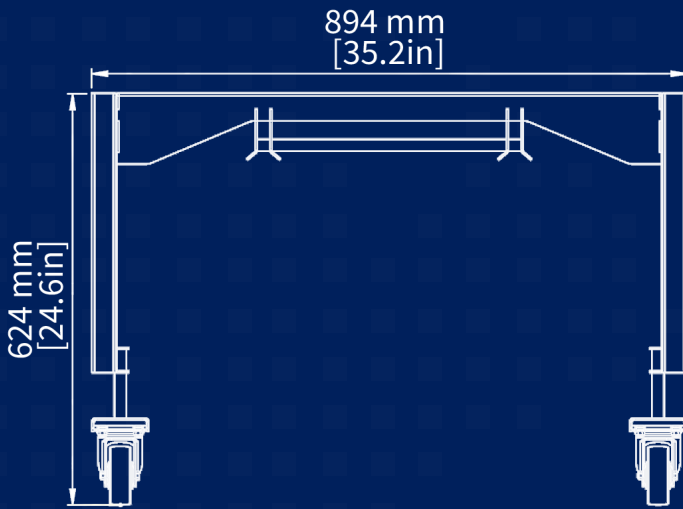

Handle

Half-Pallet Tray

Pallet Tray

Length 102 mm | 4 in

Length 651 mm | 25.6 in

Length 1 251 mm | 49.3 in

Width 894 mm | 35.2 in

Width 851 mm | 33.5 in

Width 851 mm | 33.5 in

Height 207 mm | 8.1 in

Height 37 mm | 1.5 in

Height 37 mm | 1.5 in

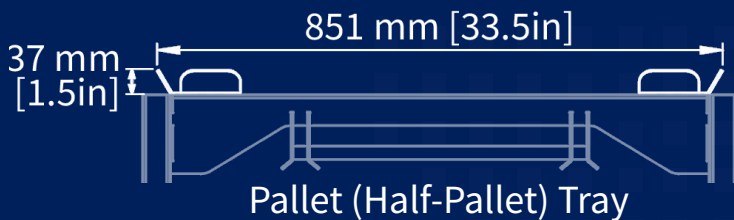

Pallet (Half-Pallet) Tray

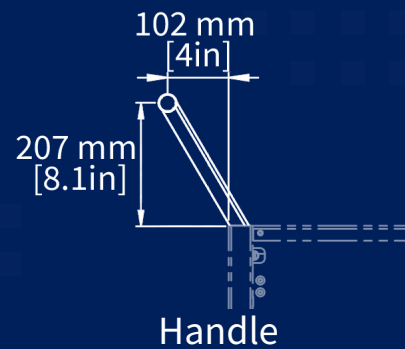

Handle



Pallet Tray



Half-pallet Tray



Basic Cart

Basic Cart with Handle

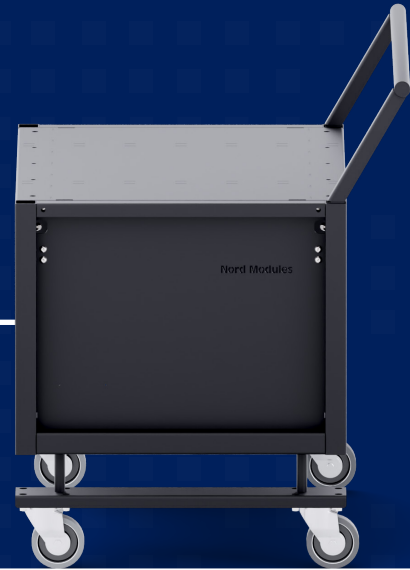

Basic Cart with Half-pallet tray

Basic Cart with Pallet tray

