

Nord Cart Mover – MiR 250

The Nord Cart Mover for MiR250 is an ultra-slim automation solution designed exclusively for the transportation of the Nord Cart 300-385. With a low profile of just 25 mm, it offers a high-capacity transport system in a remarkably compact form.

Engineered to minimize footprint and maximize efficiency, this space-saving application is the ideal choice for environments where every millimeter counts. It delivers a streamlined, reliable, and flexible solution for optimized cart handling without taking up unnecessary space.



Specifications

MiR compatibility	MiR250	Product code	Nord Cart Mover V1 - MiR 250
Weight	31.8 kg 70 lbs	Max. payload capacity	300 kg 661 lbs
Lifting speed	Up: 6.0 s – Down: 5.5 s	Stroke length	35 mm 1.4 in

Specifications may vary based on local conditions and application

Product Description

Designated use	For autonomous pickup and unload of carts with payload
Ultra-slim profile	Height of just 25 mm above the AMR platform for maximum space efficiency
Specialized docking	Secure mechanical engagement for stable cart movement
Operational precision	Engineered for perfect alignment with the Nord Cart 300-385
Infrastructure-Free	No external docking infrastructure required. The AMR navigates and docks directly to the cart for a fully flexible workflow
Full MiR Synergy	Seamlessly integrates with MiR250 software and safety systems
Reliable operation with minimal maintenance	Service intervall for every 100.000 cycles
Expected lifespan	Minimum 300.000 lifts at max. payload

Compatibility



Nord Cart 300-385



Plug-and-Play Design



Maintenance-Free Engineering



Rapid Deployment Ready



Optimized for Maximum ROI

Dimensions

Length 1 005 mm | 39.6 in

Width 568 mm | 22.4 in

Height above AMR platform 25 mm | 0.98 in

Height is measured from the top of the AMR to the top of the Cart Mover

Dimensions without AMR

Top module realized



Top module mounted on AMR

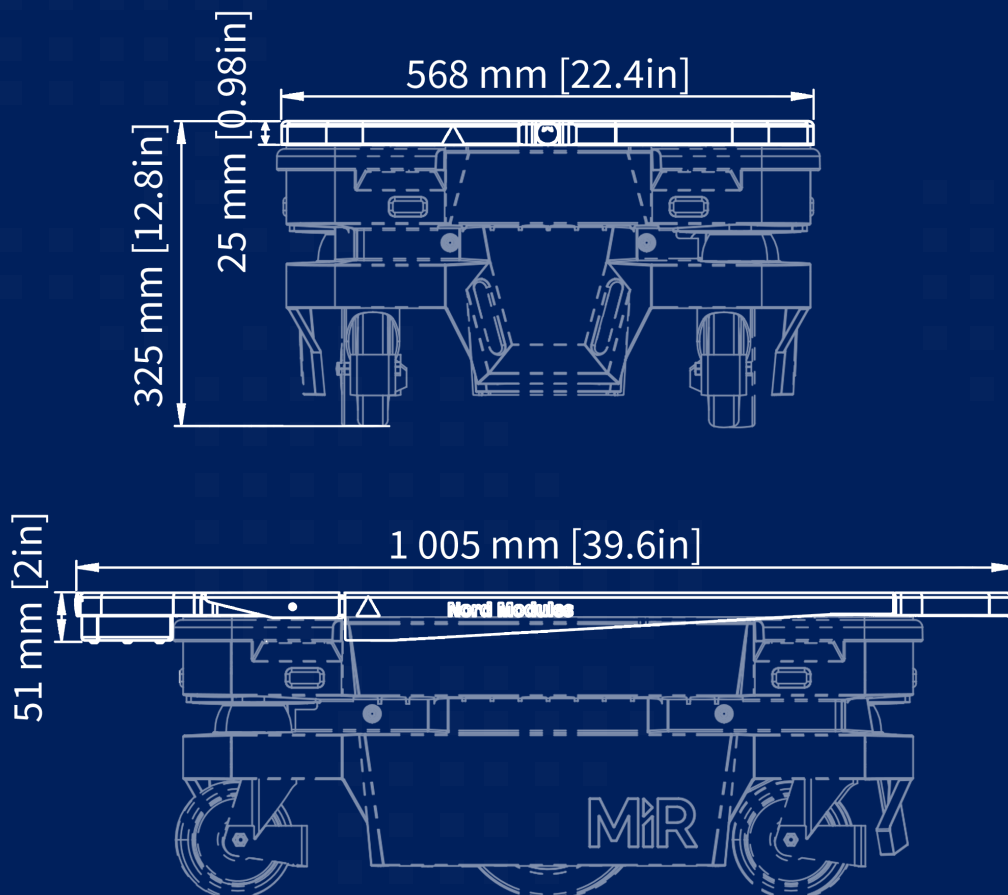

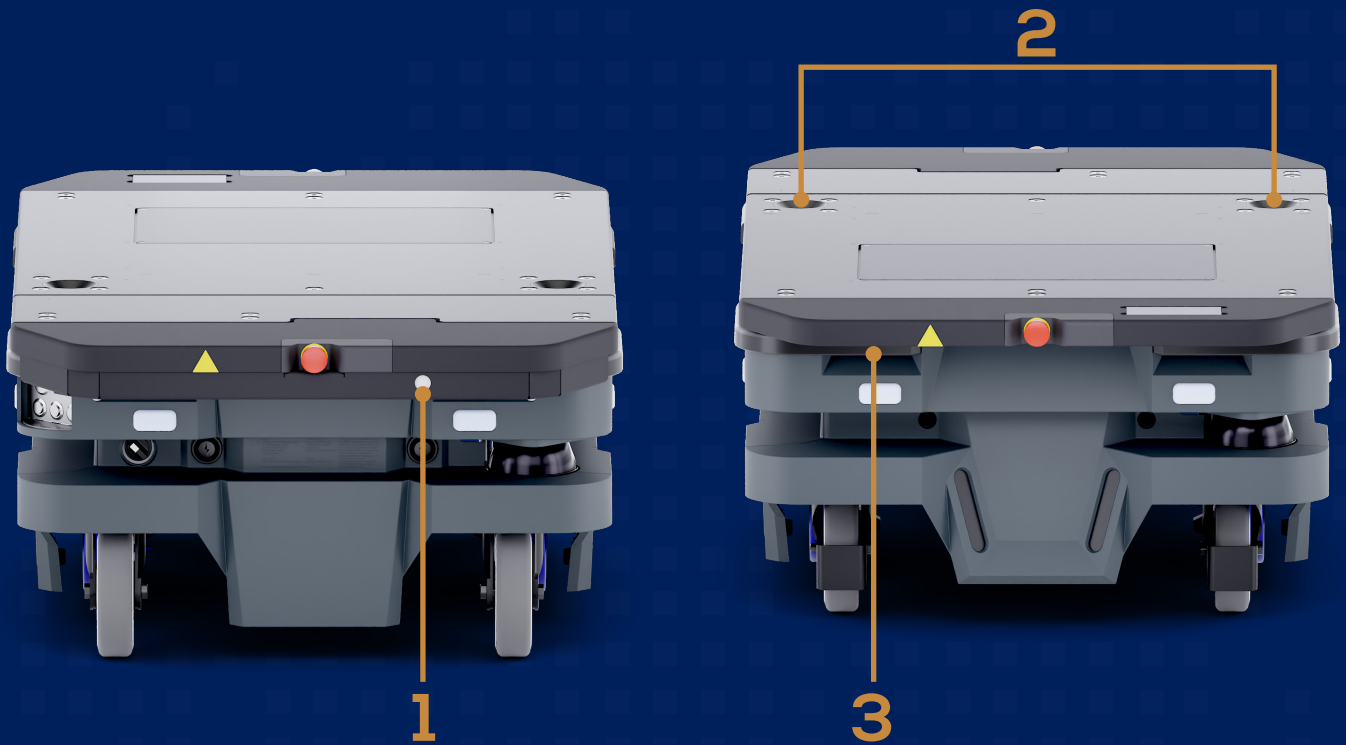

Standard

1 | Manual lowering button

Manually lowers the platform

2 | Cart Interface

Secure mechanical engagement for stable cart movement

Optional Add-ons

3 | Integrated Blue Light Kit

Lights up a blue spot on the floor in front of the AMR for extra safety

